

COLONIAL INSTRUMENTS, INC. LASER ETCHED STAINLESS STEEL TAGS

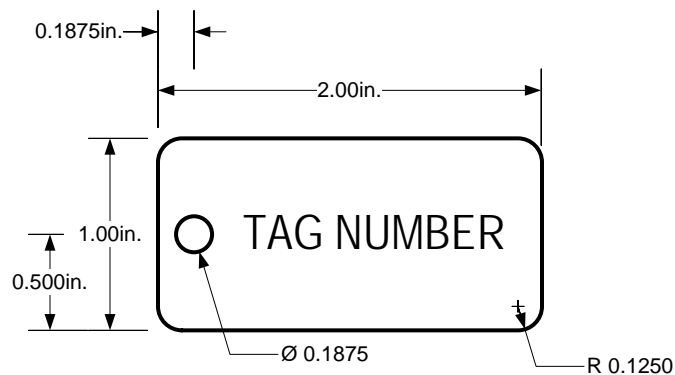

STANDARD FEATURES

Material:	304 Stainless Steel
Tag Size:	1.00" x 2.00" x 0.048"
Tag Color:	Bright Annealed Finish
Text:	Black Laser Etched
Standard Text Size:	3/8" Arial Narrow Font
3/8" Characters:	Up to 9 Per Line, Max. 1 Line
1/4" Characters:	Up to 13 Per Line, Max. 2 Lines
3/16" Characters:	Up to 18 Per Line, Max. 3 Lines
Corner:	1/8" Rounded
Hole:	3/16" Centered at Left End

TAG SPECIFICATION

Colonial Instruments P/N: SSBLE-100200R-18-H13-BA, Black Laser Etched Heavy Duty Tag, 304 Stainless Steel, 1.00" x 2.00" x 0.048" (18 Gauge), 1/8" Rounded Corners, (1) 3/16" Diameter Hole Centered at Left End, Bright Annealed Finish, with 12" x 0.020" Stainless Steel Soft Temper Attachment Wire



COLONIAL INSTRUMENTS, inc.
 ONE CHESTNUT STREET, NASHUA, NH 03060
 P: (800) 442-8437 • F: (603) 882-7878 • SALES@COLONIALGAUGES.COM

DATE: REV. 01-28-2019

DRAWN BY: JARROD WILLIAMS

COLONIAL PART NUMBER: SSBLE-100200R-18-H13-BA